

Class X Session 2023-24
Subject - Mathematics (Standard)
Sample Question Paper - 1

Time Allowed: 3 hours

Maximum Marks: 80

General Instructions:

1. This Question Paper has 5 Sections A, B, C, D and E.
2. Section A has 20 MCQs carrying 1 mark each
3. Section B has 5 questions carrying 02 marks each.
4. Section C has 6 questions carrying 03 marks each.
5. Section D has 4 questions carrying 05 marks each.
6. Section E has 3 case based integrated units of assessment (04 marks each) with sub- parts of the values of 1, 1 and 2 marks each respectively.
7. All Questions are compulsory. However, an internal choice in 2 Qs of 5 marks, 2 Qs of 3 marks and 2 Questions of 2 marks has been provided. An internal choice has been provided in the 2marks questions of Section E
8. Draw neat figures wherever required. Take $\pi = \frac{22}{7}$ wherever required if not stated.

Section A

1. The HCF and the LCM of 12, 21, 15 respectively are: [1]

- | | |
|------------|-----------|
| a) 3, 140 | b) 420, 3 |
| c) 12, 420 | d) 3, 420 |

2. Number of zeroes of the polynomial $p(x)$ shown in the Figure, are: [1]

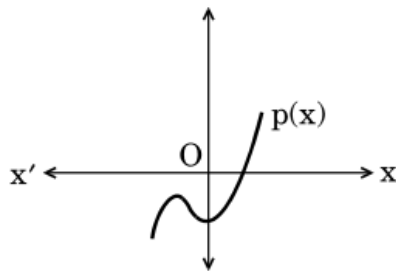

- | | |
|------|------|
| a) 2 | b) 1 |
| c) 0 | d) 3 |

3. A system of linear equations is said to be consistent, if it has [1]

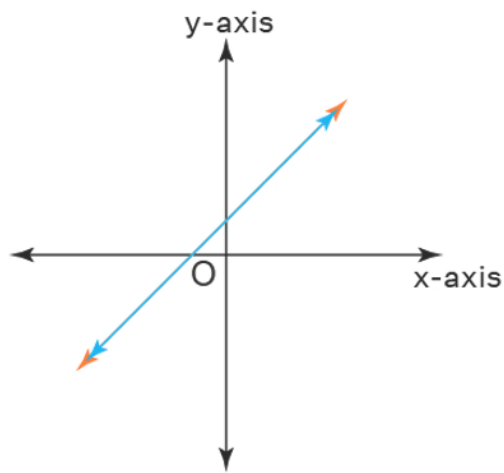

- a) two solutions
- b) one or many solutions
- c) no solution
- d) exactly one solution

4. If $x^2 + 5kx + 16 = 0$, has equal roots, then the value of k is [1]

- a) $\pm \frac{64}{25}$
- b) $\pm \frac{8}{5}$
- c) $\pm \frac{5}{8}$
- d) $\pm \frac{25}{64}$

5. The next term of the A.P. $\sqrt{18}$, $\sqrt{32}$ and $\sqrt{50}$ is [1]

- a) $\sqrt{72}$
- b) $\sqrt{84}$
- c) $\sqrt{64}$
- d) $\sqrt{80}$

6. The points P(0, 6), Q(-5, 3) and R(3,1) are the vertices of a triangle, which is [1]

- a) scalene
- b) equilateral
- c) isosceles
- d) right angled

7. The point which divides the line segment joining the points (7, -6) and (3, 4) in ratio 1 : 2 internally lies in the [1]

- a) III quadrant
- b) II quadrant
- c) I quadrant
- d) IV quadrant

8. In the given figures the measures of $\angle D$ and $\angle F$ are respectively [1]

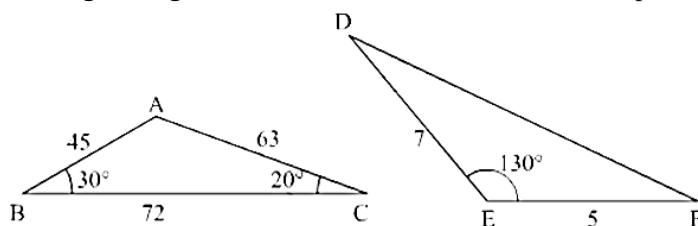

- a) $20^\circ, 30^\circ$.
- b) $30^\circ, 20^\circ$.
- c) $50^\circ, 40^\circ$.
- d) $40^\circ, 50^\circ$.

9. In figure, AB is a chord of a circle and AT is a tangent at A such that $\angle BAT = 60^\circ$, measure of $\angle ACB$ is : [1]

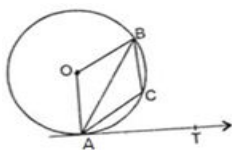

- a) 120°
- b) 150°

- c) 90° d) 110°
10. In a right triangle ABC, right angled at B, BC = 12 cm and AB = 5 cm. The radius of the circle inscribed in the triangle (in cm) is [1]
 a) 4 b) 1
 c) 2 d) 3
11. $9 \sec^2 A - 9 \tan^2 A =$ [1]
 a) 1 b) 9
 c) 0 d) 8
12. The value of $(1 + \tan^2 \theta)(1 - \sin \theta)(1 + \sin \theta)$ is [1]
 a) $\sqrt{2}$ b) 1
 c) 2 d) 0
13. The upper part of a tree broken by the wind falls to the ground without being detached. The top of the broken part touches the ground at an angle of 30° at a point 8m from the foot of the tree. The original height of the tree is [1]
 a) $8\sqrt{3}$ m b) $24\sqrt{3}$ m
 c) 8 m d) 24 m
14. A chord of a circle of radius 10 cm subtends a right angle at the centre. The area of the minor segments (given, $\pi = 3.14$) is [1]
 a) 32.5 cm^2 b) 34.5 cm^2
 c) 30.5 cm^2 d) 28.5 cm^2
15. If AB is a chord of a circle of length $5\sqrt{3}$ cm with centre O and radius 5 cm, then area of sector OAB is [1]
 a) $\frac{25\pi}{3} \text{ cm}^2$ b) $25\pi \text{ cm}^2$
 c) $\frac{8\pi}{3} \text{ cm}^2$ d) $\frac{3\pi}{8} \text{ cm}^2$
16. Cards marked with numbers 1, 2, 3, ..., 25 are placed in a box and mixed thoroughly and one card is drawn at random from the box. The probability that the number on the card is a multiple of 3 and 5 is [1]
 a) $\frac{12}{25}$ b) $\frac{4}{25}$
 c) $\frac{1}{25}$ d) $\frac{8}{25}$
17. Two dice are rolled together. The probability that the sum of the numbers that appeared is 9, is: [1]
 a) $\frac{5}{9}$ b) $\frac{1}{9}$
 c) $\frac{4}{9}$ d) $\frac{2}{9}$
18. The mean of the first 10 prime numbers is [1]
 a) 129 b) 1.29
 c) 12.9 d) 11.9
19. **Assertion (A):** If we join two hemispheres of same radius along their bases, then we get a sphere. [1]
Reason (R): A tank is made of the shape of a cylinder with a hemispherical depression at one end. The height of the cylinder is 1.45 m and radius is 30 cm. The total surface area of the tank is 3.3 m^2 .

- a) Both A and R are true and R is the correct explanation of A. b) Both A and R are true but R is not the correct explanation of A.
- c) A is true but R is false. d) A is false but R is true.

20. **Assertion (A):** The sum of the first n terms of an AP is given by $S_n = 3n^2 - 4n$. Then its n th term $a_n = 6n - 7$ [1]

Reason (R): n th term of an AP, whose sum to n terms is S_n , is given by $a_n = S_n - S_{n-1}$

- a) Both A and R are true and R is the correct explanation of A. b) Both A and R are true but R is not the correct explanation of A.
- c) A is true but R is false. d) A is false but R is true.

Section B

21. Define HCF of two positive integers and find the HCF of the pair of numbers: 105 and 120. [2]
22. If ABC and DEF are similar triangles such that $\angle A = 57^\circ$ and $\angle E = 73^\circ$, what is the measure of $\angle C$? [2]
23. In the following figure, PQ is the common tangent to both the circles. SR and PT are tangent to both the circles. If $SR = 4$ cm, $PT = 7$ cm, then find RP. [2]

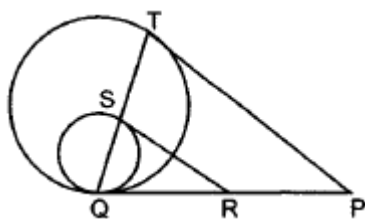

24. Evaluate: $\frac{5 \cos^2 60^\circ + 4 \sec^2 30^\circ - \tan^2 45^\circ}{\sin^2 30^\circ + \cos^2 30^\circ}$ [2]

OR

Prove that: $(\sqrt{3} + 1)(3 - \cot 30^\circ) = \tan^3 60^\circ - 2 \tan 60^\circ$

25. What is the angle subtended at the centre of a circle of radius 6 cm by an arc of length 3π cm? [2]

OR

Write the formula for the area of a segment in a circle of radius r given that the sector angle is θ (in degrees).

Section C

26. Amita, Suneha and Raghav start preparing cards for greeting each person of an old age home on new year. In order to complete one card, they take 10, 16 and 20 minutes respectively. If all of them started together, after what time will they start preparing a new card together? Why do you think there is a need to show elders that the young generation cares for them and remembers the contribution made by them in the prime of their life? [3]
27. If one root of the quadratic polynomial $2x^2 - 3x + p$ is 3, find the other root. Also, find the value of p . [3]
28. Draw the Graphs of the equations $x = 3$, $x = 5$ and $2x - y - 4 = 0$. Also find the area of the quadrilateral formed by the lines and the x-axis. [3]

OR

Check graphically whether the pair of equations $x + 3y = 6$ and $2x - 3y = 12$ is consistent. If so, solve them graphically.

29. In the given figure, two tangents RQ and RP are drawn from an external point R to the circle with centre O. If $\angle PRQ = 120^\circ$, then prove that $OR = PR + RQ$. [3]



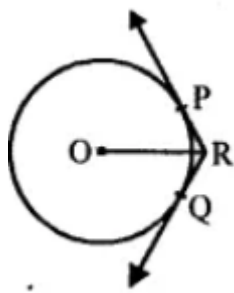

OR

In figure, from an external point P, two tangents PT and PS are drawn to a circle with centre O and radius r. If $OP = 2r$, show that $\angle OTS = \angle OST = 30^\circ$.

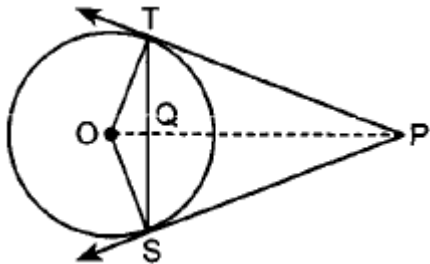

30. Find the acute angle θ , when $\frac{\cos \theta - \sin \theta}{\cos \theta + \sin \theta} = \frac{1 - \sqrt{3}}{1 + \sqrt{3}}$. [3]
31. Find the median of the following frequency distribution: [3]

Marks	0 - 10	10 - 20	20 - 30	30 - 40	40 - 50
Number of students	6	16	30	9	4

Section D

32. At t minutes past 2 p.m, the time needed by the minute hand of a clock to show 3 p.m. was found to be 3 minutes less than $\frac{t^2}{4}$ minutes. Find t . [5]

OR

A cottage industry produces a certain number of pottery articles in a day. It was observed on a particular day that cost of production of each article (in rupees) was 3 more than twice the number of articles produced on that day. If, the total cost of production on that day was ₹ 90, find the number of articles produced and the cost of each article.

33. ABCD is a quadrilateral in which $AD = BC$. If P, Q, R, S be the midpoints of AB, AC, CD and BD respectively, show that PQRS is a rhombus. [5]

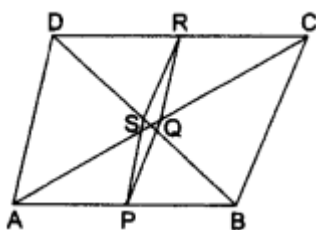

34. A tent is of the shape of a right circular cylinder upto a height of 3 metres and then becomes a right circular cone with a maximum height of 13.5 metres above the ground. Calculate the cost of painting the inner side of the tent at the rate of Rs.2 per square metre, if the radius of the base is 14 metres. [5]

OR

A tent is in the form of a right circular cylinder surmounted by a cone. The diameter of the base of the cylinder or the cone is 24 m. The height of the cylinder is 11 m. If the vertex of the cone is 16 m above the ground, find the area of the canvas required for making the tent. (Use $\pi = \frac{22}{7}$)

35. Find the mean from the following frequency distribution of marks at a test in statistics: [5]

--	--	--	--	--	--	--	--	--	--	--

Marks (x):	5	10	15	20	25	30	35	40	45	50
No. of students (f):	15	50	80	76	72	45	39	9	8	6

Section E

36. **Read the text carefully and answer the questions:** [4]

Your elder brother wants to buy a car and plans to take loan from a bank for his car. He repays his total loan of ₹ 1,18,000 by paying every month starting with the first instalment of ₹ 1000. If he increases the instalment by ₹ 100 every month, answer the following:



- (i) Find the amount paid by him in 30th installment.
- (ii) Find the amount paid by him in 30 installments.

OR

Find the 10th installment, if the 1st installment is of ₹ 2000.

- (iii) If total installments are 40 then amount paid in the last installment?

37. **Read the text carefully and answer the questions:** [4]

The design of Christmas tree is shown in the following graph:

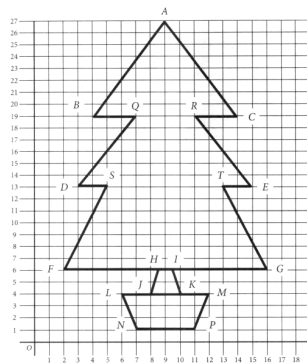

- (i) What is the distance of point A from x-axis?
- (ii) What is the Length of BC?

OR

What is the perimeter of its trunk LMPN?

- (iii) What is the Length of FG?

38. **Read the text carefully and answer the questions:** [4]

A man is watching a boat speeding away from the top of a tower. The boat makes an angle of depression of 60° with the man's eye when at a distance of 200 m from the tower. After 10 seconds, the angle of depression becomes 45°.

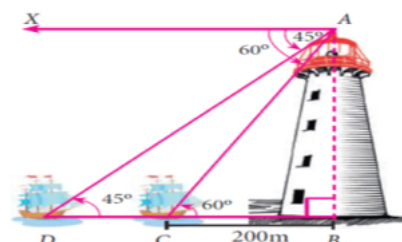

- (i) What is the approximate speed of the boat (in km/hr), assuming that it is sailing in still water?

(ii) How far is the boat when the angle is 45° ?

OR

As the boat moves away from the tower, angle of depression will decrease/increase?

(iii) What is the height of tower?

Solution

Section A

- (d) 3, 420

Explanation: We have,
 $12 = 2 \times 2 \times 3$
 $21 = 3 \times 7$
 $15 = 5 \times 3$
HCF = 3
and L.C.M = $2 \times 2 \times 3 \times 5 \times 7$
= 420
- (b) 1

Explanation: We see that the graph cuts the x-axis at 1 point which implies p(x) is zero at this 1 point only.
- (b) one or many solutions

Explanation: A system of linear equations is said to be consistent if it has at least one solution or can have many solutions. If a consistent system has an infinite number of solutions, it is dependent. When you graph the equations, both equations represent the same line. If a system has no solution, it is said to be inconsistent. The graphs of the lines do not intersect, so the graphs are parallel and there is no solution.
- (b) $\pm \frac{8}{5}$

Explanation: Here, $a = 1$, $b = 5k$, $c = 16$
If $x^2 + 5kx + 16 = 0$ has equal roots,
then, $b^2 - 4ac = 0$
 $\Rightarrow (5k)^2 - 4 \times 1 \times 16 = 0$
 $\Rightarrow 25k^2 - 64 = 0$
 $\Rightarrow 25k^2 = 64$
 $\Rightarrow k^2 = \frac{64}{25}$
 $\Rightarrow k = \pm \frac{8}{5}$
- (a) $\sqrt{72}$

Explanation: Given: $\sqrt{18}$, $\sqrt{32}$, $\sqrt{50}$
 $\Rightarrow 3\sqrt{2}$, $4\sqrt{2}$, $5\sqrt{2}$
 $\therefore d = 4\sqrt{2} - 3\sqrt{2} = \sqrt{2}$
Therefore, next term is $5\sqrt{2} + \sqrt{2}$
 $= 6\sqrt{2} = \sqrt{72}$
- (d) right angled

Explanation:



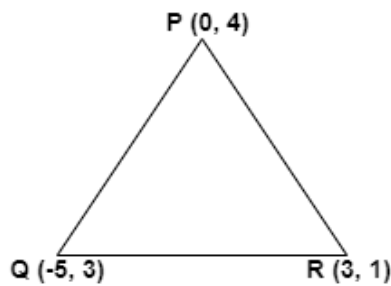

$$PQ = \sqrt{(-5)^2 + (-3)^2} = \sqrt{25 + 9}$$

$$= \sqrt{34}$$

$$QR = \sqrt{R^2 + 2^2} = \sqrt{64 + 4} = \sqrt{68}$$

$$PR = \sqrt{3^2 + 5^2} = \sqrt{9 + 25} = \sqrt{34}$$

$$PQ = PR$$

$$QR^2 = PQ^2 + PR^2$$

$$(\sqrt{68})^2 = (\sqrt{34})^2 + (\sqrt{34})^2$$

$$68 = 68$$

$\triangle PQR$ is a Isosceles right angle triangle

7.

(d) IV quadrant

Explanation: Let A and B be the joining point and P is the dividing point;

Let's assume the co - ordinates of point P = x and y

By using Section formula;

x coordinate of point P will be -

$$x = \frac{mx_2 + nx_1}{m+n} \text{ and}$$

y co - ordinate of point P will be -

$$y = \frac{my_2 + ny_1}{m+n}$$

$$\therefore x = \frac{1(3) + 2(7)}{1+2}$$

$$y = \frac{1(4) + 2(-6)}{1+2}$$

Given that,

$$x_1 = 7, y_1 = -6,$$

$$x_2 = 3, y_2 = 4$$

$$m = 1 \text{ and } n = 2$$

$$x = \frac{3+14}{3} = \frac{17}{3}$$

$$y = \frac{4-12}{3} = -\frac{8}{3}$$

So, $(x, y) = \left(\frac{17}{3}, -\frac{8}{3}\right)$ lies in IV quadrant.

[Since, in IV quadrant, x - coordinate is positive and y - coordinate is negative]

8. (a) $20^\circ, 30^\circ$.

Explanation:

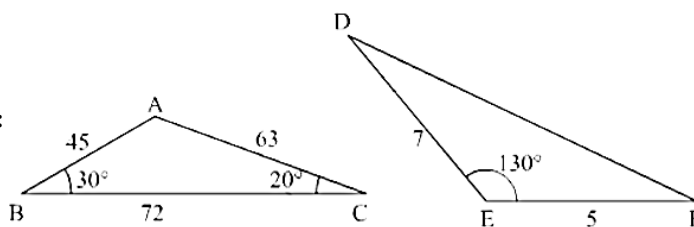

In $\triangle ABC$, $\angle A + \angle B + \angle C = 180^\circ$

$$\Rightarrow \angle A + 30^\circ + 20^\circ = 180^\circ$$

$$\Rightarrow \angle A = 130^\circ$$

Again, in $\triangle ABC$ and $\triangle DEF$,

$$\frac{AB}{AC} = \frac{DE}{EF}$$

$$\angle A = \angle E = 130^\circ$$

$$\triangle ABC \sim \triangle EFD \text{ (SAS Similarity)}$$

$$\therefore \angle F = \angle B = 30^\circ$$

$$\angle D = \angle C = 20^\circ$$

9. (a) 120°

Explanation: Since OA is perpendicular to AT, then $\angle OAT = 90^\circ$

$$\Rightarrow \angle OAB + \angle BAT = 90^\circ$$

$$\Rightarrow \angle OAB + 60^\circ = 90^\circ \Rightarrow \angle OAB = 30^\circ$$

$$\therefore \angle OAB = \angle OBA = 30^\circ \text{ [Angles opposite to radii]}$$

$$\therefore \angle AOB = 180^\circ - (30^\circ + 30^\circ) = 120^\circ \text{ [Angle sum property of a triangle]}$$

$$\therefore \text{Reflex} \angle AOB = 360^\circ - 120^\circ = 240^\circ$$

Now, since the arc AB of a circle makes an angle which is equal to twice the angle ACB subtended by it at the circumference.

$$\therefore \text{Reflex} \angle AOB = 2 \angle ACB$$

$$\Rightarrow 240^\circ = 2 \angle ACB$$

$$\Rightarrow \angle ACB = 120^\circ$$

10.

(c) 2

Explanation:

Here, $AB = 5\text{cm}$, $BC = 12$ and $\angle B = 90^\circ$

Let the radius of circle be $x\text{ cm}$

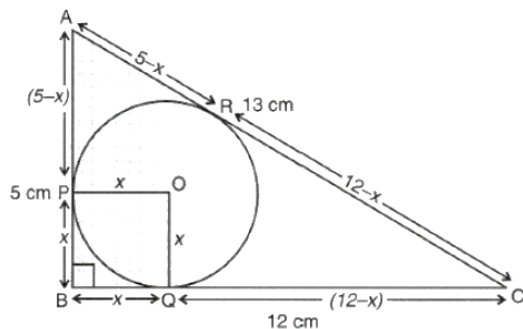

$$\therefore AC = \sqrt{(12)^2 + (5)^2}$$

$$= \sqrt{144 + 25}$$

$$= \sqrt{169} = 13\text{cm}$$

$$\therefore AC = AR + RC$$

$$\therefore AC = (5 - x) + 12 - x$$

$$\Rightarrow 13 = 5 - x + 12 - x$$

$$\Rightarrow 2x = 17 - 13 = 4$$

$$\Rightarrow x = \frac{4}{2} = 2\text{cm}$$

Hence, radius of the circle = 2cm.

11.

(b) 9

Explanation: $9(\sec^2 A - \tan^2 A)$

$$= 9 \times 1 (\sec^2 A - \tan^2 A = 1)$$

$$= 9$$

12.

(b) 1

Explanation: Given: $(1 + \tan^2 \theta)(1 - \sin \theta)(1 + \sin \theta)$

$$= (\sec^2 \theta)(1 - \sin^2 \theta)$$

$$= (\sec^2 \theta)(\cos^2 \theta)$$

$$= \frac{1}{\cos^2 \theta} \times \cos^2 \theta = 1$$

13. (a) $8\sqrt{3}\text{ m}$

Explanation: In right triangle ABC, $\cos 30^\circ = \frac{BC}{AC}$

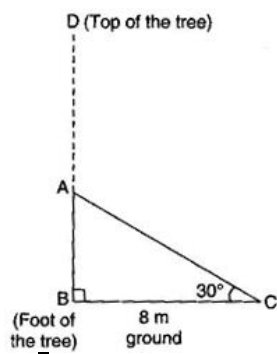

$$\Rightarrow \frac{\sqrt{3}}{2} = \frac{8}{AC} \Rightarrow AC = \frac{16}{\sqrt{3}} \text{ m}$$

Again, $\tan 30^\circ = \frac{AB}{BC}$

$$\Rightarrow \frac{1}{\sqrt{3}} = \frac{AB}{8} \Rightarrow AB = \frac{8}{\sqrt{3}} \text{ m}$$

$$\therefore \text{Height of the tree} = AB + AC = \frac{8}{\sqrt{3}} + \frac{16}{\sqrt{3}} = \frac{24}{\sqrt{3}}$$

$$= \frac{24}{\sqrt{3}} \times \frac{\sqrt{3}}{\sqrt{3}} = 8\sqrt{3} \text{ m}$$

The height of the tree is $8\sqrt{3}$ m.

14.

(d) 28.5 cm^2

Explanation:

$$\text{ar}(\text{minor segment A C B A}) = \text{ar}(\text{sector O A C B O}) - \text{ar}(\Delta OAB)$$

$$= \left(\frac{\pi r^2 \theta}{360} - \frac{1}{2} \times r \times r \right)$$

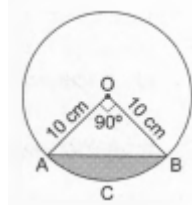

$$= \left(\frac{3.14 \times 10 \times 10 \times 90}{360} - \frac{1}{2} \times 10 \times 10 \right) \text{ cm}^2$$

$$= (78.5 - 50) \text{ cm}^2 = 28.5 \text{ cm}^2$$

15. (a) $\frac{25\pi}{3} \text{ cm}^2$

Explanation: We have to find the area of the sector OAB.

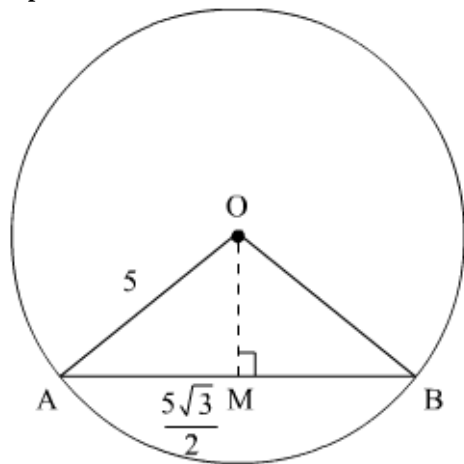

We have,

$$AM = \frac{5\sqrt{3}}{2}$$

So,

$$\sin \angle AOM = \frac{5\sqrt{3}}{2(5)}$$

Hence,

$$\angle AOM = 60^\circ$$

$$\Rightarrow \angle AOB = 120^\circ$$

$$\text{Area of sector AOB} = \frac{120}{360} \times \pi \times 5^2 \text{ cm}^2 = \frac{25\pi}{3} \text{ cm}^2$$

16.

(c) $\frac{1}{25}$

Explanation: Multiples of 3 = 3, 6, 9, 12, 15, 18, 21, 24

Multiples of 5 = 5, 10, 15, 20, 25

Number of possible outcomes (multiple of 3 and 5) = {15} = 1

Number of Total outcomes = 25

$$\therefore \text{Required Probability} = \frac{1}{25}$$

17.

(b) $\frac{1}{9}$

Explanation: Number of possible outcomes = {(3, 6), (5, 4), (4, 5), (6, 3)} = 4

Number of Total outcomes = $6 \times 6 = 36$

$$\therefore \text{Required Probability} = \frac{4}{36} = \frac{1}{9}$$

18.

(c) 12.9

Explanation: The first 10 prime numbers are 2, 3, 5, 7, 11, 13, 17, 19, 23, 29

$$\begin{aligned} \therefore \text{Mean} &= \frac{\text{Sum of first 10 prime numbers}}{10} \\ &= \frac{2+3+5+7+11+13+17+19+23+29}{10} \\ &= \frac{129}{10} \\ &= 12.9 \end{aligned}$$

19.

(b) Both A and R are true but R is not the correct explanation of A.

Explanation: Both A and R are true but R is not the correct explanation of A.

20. (a) Both A and R are true and R is the correct explanation of A.

Explanation: nth term of an AP be $a_n = S_n - S_{n-1}$

$$a_n = 3n^2 - 4n - 3(n-1)^2 + 4(n-1)$$

$$a_n = 6n - 7$$

So, both A and R are true and R is the correct explanation of A.

Section B

21. HCF of two or more numbers is the greatest common factor which can divide all the numbers exactly.

On applying Euclid's division lemma on 120 and 105 we get

$$120 = 105 \times 1 + 15.$$

Since remainder $\neq 0$, apply division lemma on divisor 105 and remainder 15

$$105 = 15 \times 7 + 0.$$

Therefore, H.C.F. of 105 and 120 = 15.

22. It is given that $\triangle ABC \sim \triangle DEF$

Their corresponding angles are equal, $\angle A = \angle D$, $\angle B = \angle E$ and $\angle C = \angle F$

But $\angle A = 57^\circ$

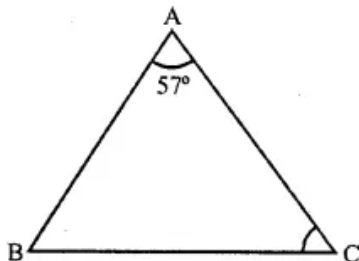

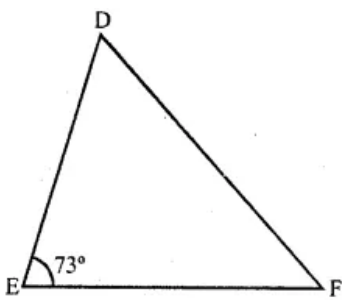

$$\therefore \angle D = 57^\circ$$

$$\therefore \angle E = 73^\circ$$

$$\therefore \angle B = 73^\circ$$

Now in $\triangle ABC$

$$\angle A + \angle B + \angle C = 180^\circ \text{ (Sum of angles of a triangle)}$$

$$\Rightarrow 57^\circ + 73^\circ + \angle C = 180^\circ$$

$$\Rightarrow 130^\circ + \angle C = 180^\circ \Rightarrow \angle C = 180^\circ - 130^\circ$$

$$\therefore \angle C = 50^\circ$$

23. $\therefore PT = PQ$

$$\therefore PQ = 7 \text{ cm}$$

Also $SR = QR$

$$\therefore QR = 4$$

$$\text{Now, } RP = PQ - QR = 7 - 4 = 3 \text{ cm}$$

24. Given: $\frac{5 \cos^2 60^\circ + 4 \sec^2 30^\circ - \tan^2 45^\circ}{\sin^2 30^\circ + \cos^2 30^\circ}$

$$= \frac{5\left(\frac{1}{2}\right)^2 + 4\left(\frac{2}{\sqrt{3}}\right)^2 - (1)^2}{\left(\frac{1}{2}\right)^2 + \left(\frac{\sqrt{3}}{2}\right)^2}$$

$$= \frac{5 \times \frac{1}{4} + 4 \times \frac{4}{3} - 1}{\frac{1}{4} + \frac{3}{4}}$$

$$= \frac{\frac{5}{4} + \frac{16}{3} - 1}{\frac{1+3}{4}}$$

$$= \frac{\frac{15+64-12}{12}}{\frac{4}{4}}$$

$$= \frac{67}{12}$$

$$= \frac{67}{12}$$

$$= \frac{67}{12}$$

$$= \frac{67}{12}$$

OR

$$\text{We have to prove that: } (\sqrt{3} + 1)(3 - \cot 30^\circ) = \tan^3 60^\circ - 2 \tan 60^\circ$$

$$\text{Here, LHS} = (\sqrt{3} + 1)(3 - \cot 30^\circ)$$

$$= (\sqrt{3} + 1)(3 - \sqrt{3})$$

$$= \sqrt{3}(3 - \sqrt{3}) + 1(3 - \sqrt{3})$$

$$= 3\sqrt{3} - 3 + 3 - \sqrt{3}$$

$$= 2\sqrt{3}$$

$$\text{RHS} = \tan^3 60^\circ - 2 \sin 60^\circ$$

$$= (\sqrt{3})^3 - 2 \times \frac{\sqrt{3}}{2}$$

$$= 3\sqrt{3} - \sqrt{3}$$

$$= 2\sqrt{3}$$

$$\Rightarrow \text{LHS} = \text{RHS}$$

Hence, proved.

25. We have

$$R = 6 \text{ cm}$$

$$\text{Length of the arc} = 3\pi \text{ cm}$$

$$\text{as we know that arc length} = \frac{\theta}{360} \times 2\pi r$$

Substituting the values we get,

$$3\pi = \frac{\theta}{360} \times 2\pi \times 6 \dots(1)$$

Now we will simplify the equation (1) as below,

$$3\pi = \frac{\theta}{360} \times 12\pi$$

$$3\pi = \frac{\theta}{30} \times \pi$$

$$3 = \frac{\theta}{30}$$

$$\theta = 90^\circ$$

Therefore, the angle subtended at the centre of the circle is 90° .

OR

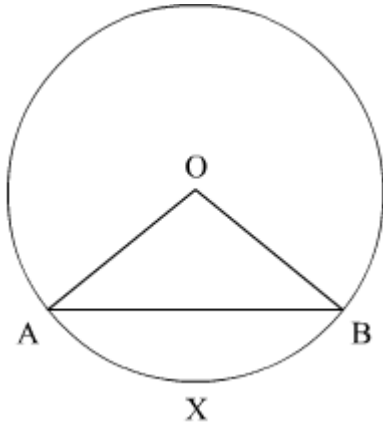

In this figure, centre of the circle is O , radius $OA = r$ and $\angle AOB = \theta$

We are going to find the area of the segment AXB .

Area of the segment $AXB = \text{Area of the sector } OAXB - \text{Area of } \triangle AOB \dots(i)$

We know that area of sector $OAXB = \frac{\theta}{360} \times \pi r^2$

We also know that area of $\triangle AOB = r^2 \sin \frac{\theta}{2} \cos \frac{\theta}{2}$

Substituting these values in equation (1) we get,

$$\text{Area of the segment } AXB = \frac{\theta}{360} \times \pi r^2 - r^2 \sin \frac{\theta}{2} \cos \frac{\theta}{2}$$

$$\text{Area of the segment } AXB = \left(\frac{\theta}{360} \times \pi - \sin \frac{\theta}{2} \cos \frac{\theta}{2} \right) r^2$$

$$\text{So, Area of the segment } AXB = \left(\frac{\pi\theta}{360} - \sin \frac{\theta}{2} \cos \frac{\theta}{2} \right) r^2$$

$$\text{Therefore, area of the segment is } \left(\frac{\pi\theta}{360} - \sin \frac{\theta}{2} \cos \frac{\theta}{2} \right) r^2$$

Section C

26. (i) The required number of minutes after which they start preparing a new card together = LCM of 10,16 and 20 minutes

Prime factorisation of $10 = 2 \times 5$

and prime factorisation of $16 = 2 \times 2 \times 2 \times 2$

and prime factorisation of $20 = 2 \times 2 \times 5$

Now, $\text{LCM}(10,16,20) = 2 \times 2 \times 2 \times 2 \times 5 = 80$

Therefore, Number of minutes after which they start preparing a new card together = 80 minutes.

(ii) Recognition and care for elders removes the loneliness due to age related diseases. Moreover they feel happy to help young minds through their experience.

27. The given quadratic polynomial is $p(x) = 2x^2 - 3x + p$

Since, 3 is a root (zero) of $p(x)$

$$\Rightarrow 2(3)^2 - 3 \times 3 + p = 0$$

$$\Rightarrow 18 - 9 + p = 0$$

$$\Rightarrow 9 + p = 0$$

$$\Rightarrow p = -9$$

$$\text{Now } p(x) = 2x^2 - 3x - 9$$

$$= 2x^2 - 6x + 3x - 9$$

$$= 2x(x - 3) + 3(x - 3)$$

$$= (x - 3)(2x + 3)$$

For roots of polynomial, $p(x) = 0$

$$\Rightarrow (x - 3)(2x + 3) = 0$$

$$\Rightarrow x = 3 \text{ or } x = -\frac{3}{2}$$

Hence the other root is $-\frac{3}{2}$.

28. $2x - y = 4$

x	2	3	5
y	0	2	6

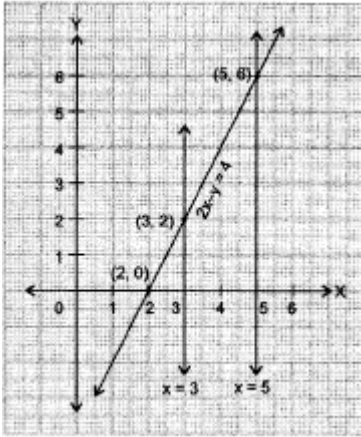

Quadrilateral is like trapezium whose parallel sides are 2 units and 6 units . Distance between parallel sides is 2 units .

So, area of trapezium = $\frac{1}{2} \times (\text{sum of parallel sides}) \times (\text{Distance between parallel sides})$

$$= \frac{1}{2}(2 + 6) \times 2 = 8 \text{ sq. units}$$

OR

The solution of pair of linear equations:

$$x + 3y = 6 \text{ and } 2x - 3y = 12$$

x	0	6
$y = \frac{6-x}{3}$	2	0

and

x	0	3
$y = \frac{2x-12}{3}$	-4	-2

Plot the points A(0, 2), B(6, 0), P(0, -4) and Q(3, -2) on graph paper, and join the points to form the lines AB and PQ

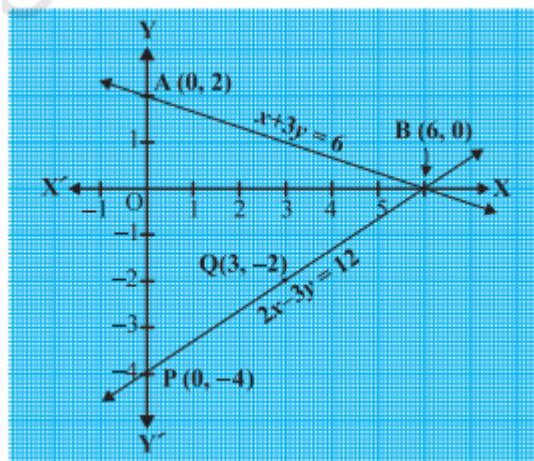

We observe that there is a point B (6, 0) common to both the lines AB and PQ. So, the solution of the pair of linear equations is $x = 6$ and $y = 0$, i.e., the given pair of equations is consistent.

29. In the given figure, two tangents RQ and RP are drawn from the external point R to the circle with centre O.

$$\angle PRQ = 120^\circ$$

To prove: $OR = PR + RQ$

Construction: Join OP and OQ.

Also join OR.

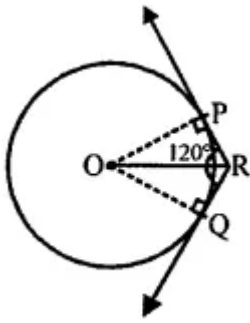

Proof: OR bisects the $\angle PRQ$

$$\therefore \angle PRO = \angle QRO = \frac{120^\circ}{2} = 60^\circ$$

\therefore OP and OQ are radii and RP and RQ are tangents.

\therefore OP \perp PR and OQ \perp QR

In right $\triangle OPR$

$$\begin{aligned} \angle POR &= 180^\circ - (90^\circ + 60^\circ) \\ &= 180^\circ - 150^\circ = 30^\circ \end{aligned}$$

Similarly,

$$\angle QOR = 30^\circ$$

$$\text{and } \cos \theta = \frac{PR}{OR}$$

$$\Rightarrow \cos 60^\circ = \frac{PR}{OR} \Rightarrow \frac{1}{2} = \frac{PR}{OR}$$

$$\Rightarrow 2PR = OR \dots\dots(i)$$

Similarly, in right $\triangle OQR$

$$\Rightarrow 2QR = OR \dots\dots(ii)$$

Adding (i) and (ii)

$$\Rightarrow 2PR + 2QR = 2OR$$

$$\Rightarrow OR = PR + RQ$$

Hence Proved.

OR

Given,

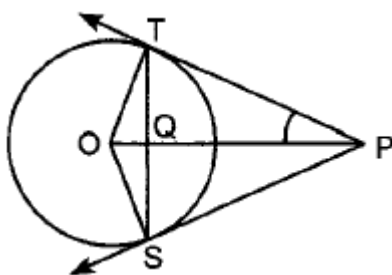

In $\triangle OTS$,

$$OT = OS$$

$$\Rightarrow \angle OTS = \angle OST \dots(i)$$

In right $\triangle OTP$,

$$\frac{OT}{OP} = \sin \angle TPO$$

$$\Rightarrow \frac{r}{2r} = \sin \angle TPO$$

$$\sin \angle TPO = \frac{1}{2} \Rightarrow \angle TPO = 30^\circ$$

Similarly $\angle OPS = 30^\circ$

$$\Rightarrow \angle TPS = 30^\circ + 30^\circ = 60^\circ$$

Also $\angle TPS + \angle SOT = 180^\circ$

$$\Rightarrow \angle SOT = 120^\circ$$

In $\triangle SOT$,

$$\angle SOT + \angle OTS + \angle OST = 180^\circ$$

$$\Rightarrow 120^\circ + 2\angle OTS = 180^\circ$$

$$\Rightarrow \angle OTS = 30^\circ \dots(ii)$$

From (i) and (ii)

$$\angle OTS = \angle OST = 30^\circ$$

30. According to question

$$\frac{\cos \theta - \sin \theta}{\cos \theta + \sin \theta} = \frac{1 - \sqrt{3}}{1 + \sqrt{3}}$$

$$\Rightarrow \frac{(\cos \theta - \sin \theta) + (\cos \theta + \sin \theta)}{(\cos \theta - \sin \theta) - (\cos \theta + \sin \theta)} = \frac{(1 - \sqrt{3}) + (1 + \sqrt{3})}{(1 - \sqrt{3}) - (1 + \sqrt{3})} \quad [\text{Applying componendo and dividendo}]$$

$$\Rightarrow \frac{2 \cos \theta}{-2 \sin \theta} = \frac{2}{-2\sqrt{3}}$$

$$\Rightarrow \cot \theta = \frac{1}{\sqrt{3}} \Rightarrow \tan \theta = \sqrt{3} \Rightarrow \tan \theta = \tan 60^\circ \Rightarrow \theta = 60^\circ$$

Class Interval	Frequency	Cumulative Frequency
0 - 10	6	6
10 - 20	16	22
20 - 30	30	52
30 - 40	9	61
40 - 50	4	65

31. Here, $N = 65 \Rightarrow \frac{N}{2} = 32.5$

The cumulative frequency just greater than 32.5 is 52.

Hence, median class is 20 - 30.

$\therefore l = 20, h = 10, f = 30, cf = cf \text{ of preceding class} = 22$

$$\text{Now, Median} = l + \left\{ h \times \frac{\left(\frac{N}{2} - cf\right)}{f} \right\}$$

$$= 20 + \left\{ 10 \times \frac{(32.5 - 22)}{30} \right\}$$

$$= 20 + \left\{ 10 \times \frac{10.5}{30} \right\}$$

$$= 20 + 3.5$$

$$= 23.5$$

Thus, the median of the data is 23.5.

Section D

32. Total time taken by minute hand from 2 p.m. to 3 p.m. is 60 min.

According to question,

$$t + \left(\frac{t^2}{4} - 3 \right) = 60$$

$$\Rightarrow 4t + t^2 - 12 = 240$$

$$\Rightarrow t^2 + 4t - 252 = 0$$

$$\Rightarrow t^2 + 18t - 14t - 252 = 0$$

$$\Rightarrow t(t + 18) - 14(t + 18) = 0$$

$$\Rightarrow (t + 18)(t - 14) = 0$$

$$\Rightarrow t + 18 = 0 \text{ or } t - 14 = 0$$

$$\Rightarrow t = -18 \text{ or } t = 14 \text{ min.}$$

As time can't be negative.

Therefore, $t = 14$ min.

OR

Let cost of production of each article be Rs x

We are given total cost of production on that particular day = Rs 90

Therefore, total number of articles produced that day = $90/x$

According to the given conditions,

$$x = 2 \left(\frac{90}{x} \right) + 3$$

$$\Rightarrow x = \frac{180}{x} + 3$$

$$\Rightarrow x = \frac{180 + 3x}{x}$$

$$\Rightarrow x^2 = 180 + 3x$$

$$\Rightarrow x^2 - 3x - 180 = 0$$

$$\Rightarrow x^2 - 15x + 12x - 180 = 0$$

$$\Rightarrow x(x - 15) + 12(x - 15) = 0$$

$$\Rightarrow (x - 15)(x + 12) = 0 \Rightarrow x = 15, -12$$

Cost cannot be in negative, therefore, we discard $x = -12$

Therefore, $x = Rs 15$ which is the cost of production of each article.

Number of articles produced on that particular day = $\frac{90}{15} = 6$

33. Given: ABCD is a quadrilateral in which $AD = BC$. P, Q, R, S are the midpoints of AB, AC, CD and BD.

To prove: PQRS is a rhombus

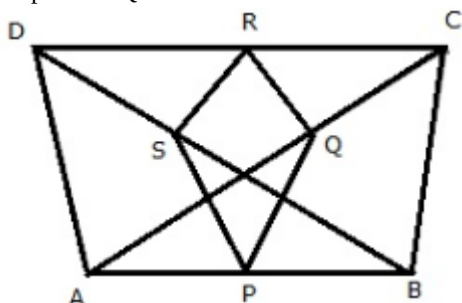

Proof: In $\triangle ABC$,

Since P and Q are mid points of AB and AC

Therefore, $PQ \parallel BC$, $PQ = \frac{1}{2}BC$ (1) (Mid-point theorem)

Similarly,

In $\triangle CDA$,

Since R and Q are mid points of CD and AC

Therefore, $RQ \parallel DA$, $RQ = \frac{1}{2}DA = \frac{1}{2}BC$ (2)

In $\triangle BDA$,

Since S and P mid points of BD and AB

Therefore, $SP \parallel DA$, $SP = \frac{1}{2}DA = \frac{1}{2}BC$ (3)

In $\triangle CDB$,

Since S and R are mid points of BD and CD

Therefore, $SR \parallel BC$, $SR = \frac{1}{2}BC$ (4)

From (1) (2),(3) and (4) $PQ \parallel SR$ and (3) $RQ \parallel SP$

$PQ = RQ = SP = SR$

So the opposite sides of PQRS are parallel and all sides are equal

Hence, PQRS is a rhombus.

34. Let r metres be the radius of the base of the cylinder and h metres be its height $\Rightarrow l_1 = \sqrt{306.25}m = 17.5m$

Then, $r = 14m$ and $h = 3m$

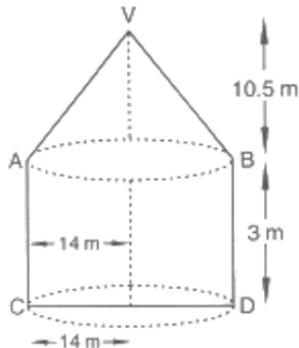

Now we have Curved surface area of the cylinder $= 2\pi rhm^2 = \left(2 \times \frac{22}{7} \times 14 \times 3\right) m^2 = 264 m^2$

Let r_1 m be the radius of the base, h_1 m be the height and Z m be the slant height of the cone. Then, $r_1 = 14m$, $h_1 = (13.5 - 3)m = 10.5m$

$$\therefore l_1 = \sqrt{r_1^2 + h_1^2}$$

$$\Rightarrow l_1 = \sqrt{14^2 + (10.5)^2}m = \sqrt{196 + 110.25}m$$

Therefore Curved surface area of the cone = $\pi r_1 l_1$

$$= \frac{22}{7} \times 14 \times 17.5m^2 = 770m^2$$

So, Total area which is to be painted = Curved surface area of the cylinder + Curved surface area of the cone...

$$= (264 + 770) \text{ m}^2 = 1034 \text{ m}^2$$

Now for Fence, total cost of painting = Rs.(1034 × 2) = Rs.2068 .

OR

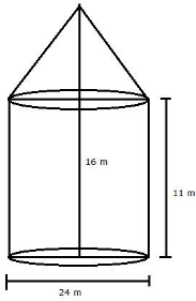

Diameter of cylinder = 24m

∴ radius of cylinder = radius of cone = 12m

Height of cylinder = 11m

Total height of tent = 16m

∴ Height of cone = 16 - 11 = 5m

$$\text{Now, } l^2 = r^2 + h^2$$

$$\Rightarrow l^2 = 12^2 + 5^2$$

$$\Rightarrow l^2 = 144 + 25 = 169$$

$$\Rightarrow l = \sqrt{169} = 13\text{m}$$

∴ Canvas required for tent = curved surface area of cone + curved surface area of cylinder

$$= \pi r l + 2\pi r h$$

$$= \frac{22}{7} \times 12 \times 13 + 2 \times \frac{22}{7} \times 12 \times 11$$

$$= \frac{22}{7} \times 12 [13 + 2 \times 11]$$

$$= \frac{22}{7} \times 12 \times 35$$

$$= 22 \times 12 \times 5 = 1320\text{m}^2$$

35. Let the assumed mean be $A = 25$ and $h = 5$.

marks (x_1):	no. of students (f_1):	$d_1 = x_1 - A = x_1 - 25$	$u_1 = \frac{1}{h}(d_1)$	$f_1 u_1$
5	15	-20	-4	-60
10	50	-15	-3	-150
15	80	-10	-2	-160
20	76	-5	-1	-76
25	72	0	0	0
30	45	5	1	45
35	39	10	2	78
30	9	15	3	27
45	8	20	4	32
50	6	25	5	30
	$\sum f_1 = 400$			$\sum f_1 u_1 = -234$

We know that mean, $\bar{X} = A + h \left(\frac{1}{N} \sum_{i=1}^n f_i u_i \right)$

Now, we have $N = \sum f_1 = 400$, $\sum f_1 u_1 = -234$, $h = 5$ and $A = 25$.

Putting the values in the above formula, we get

$$\bar{X} = A + h \left(\frac{1}{N} \sum_{i=1}^n f_i u_i \right)$$

$$\begin{aligned}
 &= 25 + 5 \left(\frac{1}{400} \times (-234) \right) \\
 &= 25 - \frac{234}{80} \\
 &= 25 - 2.925 \\
 &= 22.075
 \end{aligned}$$

Hence, the mean marks is 22.075

Section E

36. Read the text carefully and answer the questions:

Your elder brother wants to buy a car and plans to take loan from a bank for his car. He repays his total loan of ₹ 1,18,000 by paying every month starting with the first instalment of ₹ 1000. If he increases the instalment by ₹ 100 every month, answer the following:



(i) $a = 1000$

$d = 100$

$S_n = 1,18,000$

$t_{30} = a + 29d$

$= 1000 + 29 \times 100$

$= 1000 + 2900$

$t_{30} = 3900$

i.e., he will pay ₹ 3900 in 30th installment.

(ii) $S_n = \frac{n}{2} \{2a + (n - 1)d\}$

$S_{30} = \frac{30}{2} \{2 \times 1000 + (30 - 1) \times 100\}$

$S_{30} = 15 \{2000 + 2900\}$

$S_{30} = 15 \times 4900$

$S_{30} = 73,500$

i.e., he will pay ₹ 73500 in 30 installments.

OR

$t_{10} = a + 9d$

$= 2000 + 9 \times 100$

$t_{10} = 2000 + 900$

$t_{10} = ₹ 2900$

(iii) $S_n = \frac{n}{2} \{a + l\}$

$1,18,000 = \frac{40}{2} \{1000 + l\}$

$1,18,000 = 20,000 + 20l$

$98,000 = 20l$

$l = 4900$

i.e., the last installment will be of ₹ 4900.

37. Read the text carefully and answer the questions:

The design of Christmas tree is shown in the following graph:

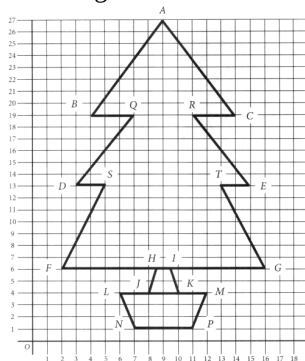

(i) The coordinates of point A are (9, 27), therefore its distance from x-axis = 27 units.

(ii) Coordinates of B and C are (4, 19) and (14, 19)

$$\begin{aligned} \therefore \text{Required distance} &= \sqrt{(14 - 4)^2 + (19 - 19)^2} \\ &= \sqrt{10^2} = 10 \text{ units} \end{aligned}$$

OR

Coordinates of L and N are (6, 4) and (7, 1) respectively.

$$\begin{aligned} \text{Length of LN} &= \sqrt{(7 - 6)^2 + (1 - 4)^2} \\ &= \sqrt{1 + 9} = \sqrt{10} \text{ units} \end{aligned}$$

$$\Rightarrow \text{Length of MP} = \sqrt{10} \text{ units}$$

Now, perimeter of LMPN = LN + LM + MP + NP

$$= \sqrt{10} + 6 + \sqrt{10} + 4 = (2\sqrt{10} + 10) \text{ units} [\because \text{LM} = 12 - 6 = 6 \text{ units and NP} = 11 - 7 = 4 \text{ units}]$$

(iii) Coordinates of F and G are (2, 6) and (16, 6) respectively.

$$\begin{aligned} \therefore \text{Required distance} &= \sqrt{(16 - 2)^2 + (6 - 6)^2} \\ &= \sqrt{14^2} = 14 \text{ units} \end{aligned}$$

38. Read the text carefully and answer the questions:

A man is watching a boat speeding away from the top of a tower. The boat makes an angle of depression of 60° with the man's eye when at a distance of 200 m from the tower. After 10 seconds, the angle of depression becomes 45° .

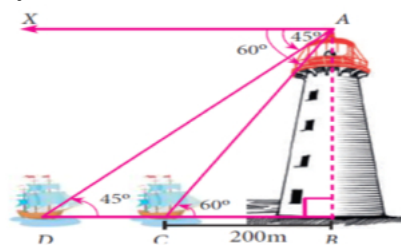

(i) In $\triangle ABC$

$$\tan 60^\circ = \frac{AB}{BC}$$

$$\sqrt{3} = \frac{AB}{200}$$

$$AB = 200\sqrt{3}$$

Now, In $\triangle ABD$

$$\tan 45^\circ = \frac{AB}{BD}$$

$$1 = \frac{200\sqrt{3}}{BD}$$

$$BD = 200\sqrt{3}$$

$$\therefore CD = BD - BC$$

$$= 200\sqrt{3} - 200$$

$$= 200(\sqrt{3} - 1)$$

$$= 200 \times (1.732 - 1)$$

$$= 200 \times 0.732$$

$$= 146.4 \text{ m}$$

$$\text{speed} = \frac{\text{distance}}{\text{time}}$$

$$= \frac{146.4}{10}$$

$$= 14.64 \text{ m/s}$$

Now,

$$\text{speed} = 14.64 \times \frac{18}{5} \text{ km/hr}$$

$$= 52.7$$

$$\approx 53 \text{ km/hr}$$

(ii) In $\triangle ABD$

$$\tan 45^\circ = \frac{AB}{BD}$$

$$1 = \frac{200\sqrt{3}}{BD}$$

$$BD = 200\sqrt{3} \text{ m}$$

$$\therefore CD = 200\sqrt{3} - 200$$

$$= 200(\sqrt{3} - 1)$$

$$= 200(1.732 - 1)$$

$$= 200 \times 0.732$$

$$= 146.4$$

$$\approx 147 \text{ m}$$

\therefore boat is at a distance of 147 m from its actual position.

OR

As boat moves away from the tower angle of depression decreases.

(iii) In $\triangle ABC$

$$\tan 60^\circ = \frac{AB}{BC}$$

$$\sqrt{3} = \frac{AB}{200}$$

$$AB = 200\sqrt{3} \text{ m}$$

Hence, height of tower = $200\sqrt{3} \text{ m}$